

PLASPLUGS[®]

A range of complementary
Tile Care & Maintenance products



Heavy Duty
Tile Cleaner



Grout Cleaner &
Mould Remover



Tile Clean &
Shine

Installing New Tiles

- Tile Sealer TLIMP110
- Wax & Polish Remover WPR100
- Terracotta Shine Seal TCSS112
- Floor Tile Polish FTP105

Renovation

- Heavy Duty Tile Cleaner HDTCL111
- Grout Cleaner GCL107
- Mould Remover MSPR109

Maintenance

- Tile Clean & Shine SFL101
- Marble Clean & Shine MCS104
- Bathroom & Wall Tile Cleaner BWCL108
- Laminate Clean & Shine LCS103



Waste electrical products should not be
disposed of with household waste.
Please recycle where facilities exist.
Check with your local authority or retailer
for recycling advice.

PLASPLUGS[®]

Plasplugs Ltd

Wetmore Road Burton on Trent Staffordshire DE14 1SD UK

Tel: +44(0) 1283 530303 Fax: +44(0) 1283 531246

www.plasplugs.com

© 2002 Plasplugs Ltd

Due to minor changes in design or otherwise, the product you buy may differ slightly from
the one shown in this manual. Approved by EEC Standards

Part No: 062513264/Rev1

PLASPLUGS[®]

PRO-TILER PLUS TILE CUTTER

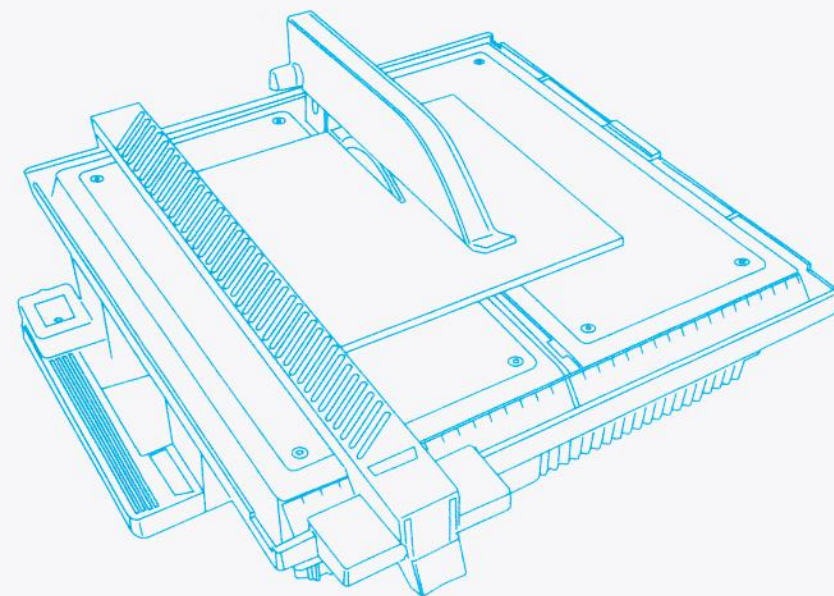

MODEL NO: DWW110

FOR YOUR SAFETY. PLEASE READ BEFORE USE.

SAVE THESE INSTRUCTIONS KEEP IN A SAFE PLACE

When using electrical tools, basic safety precautions should be always used including the following:

- Read and save all instructions.
- **Connect through an RCD adaptor.**
- Unplug from outlet when not in use, before putting on or taking off any parts and before cleaning.
- To protect against electrical shock, do not immerse cord, plug or appliance in water or any other liquid.
- Do not operate any product with a damaged cord or plug, if the product malfunctions or it is dropped or damaged in any way.
- The use of attachments not recommended or sold by Plasplugs may cause fire, electrical shock or injury.
- Keep your work area clean – Cluttered benches invite accidents.
- Do not use in dangerous environments. Do not use in damp or wet conditions or expose machine in rain. Keep your working area well lit.
- Do not let the cord hang over the edge of table or counter or touch hot surfaces.
- Do not use product or attachments for other than intended purpose.
- Do not leave product unattended whilst it is operating.
- Do not overreach – keep proper footing and balance at all times.
- Keep all non-users a safe distance from the work area, especially children.
- Never touch the moving cutting wheel.
- Grinding generates sparks – keep away all flammable substances and materials.
- Maintain all tools with care. Keep tools sharp and clean for best and safest performance.
- To reduce the risk of unintentional starting, make sure that the switch is in the off position before plugging in.
- Never stand on tools.
- Always check for damaged parts before operation. Damaged parts should be properly repaired and replaced.
- Use extension cords intended for outdoor use. Ensure that the electrical rating and cord length is correct for the tool. Do not use damaged extension cords.
- Thermal cut out switch (specified on rating label). This will prevent the motor from over heating etc.

USER PRECAUTIONS

- Wear proper apparel – remove all loose clothing, neckties, rings, bracelets and other jewellery that may get caught in moving parts.
- Non-slip footwear is recommended.
- Wear protective hair covering to contain long hair.
- Ear protection and gloves are recommended.
- Always use safety glasses. NB Everyday eye-glasses do not contain impact resistant lenses – they are NOT safety glasses.
-  Always use face or dust masks if cutting operation is dusty.
-  **Always connect to an electrical power point using an approved RCD circuit breaker.**
- **This is an essential safety precaution.**
- For safety and to prolong the motor life, only switch the Tile Cutter on before cutting a tile. Switch off immediately after use.

INTRODUCING YOUR PLASPLUGS PRO-TILER PLUS TILE CUTTER

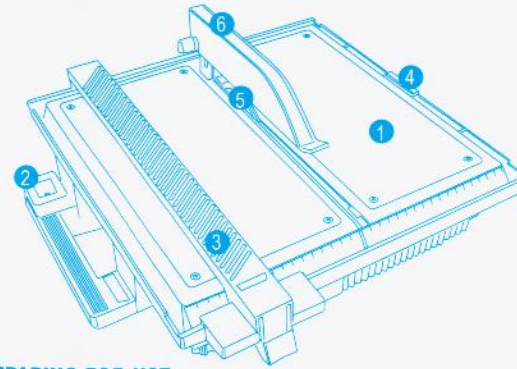

1. Motor Base Unit & Water Reservoir
2. Power Switch
3. Cutter Guide
4. Water Reservoir Cover/Mitre Guide
5. Diamond Cutting Blade, Washer, Nut
6. Splash Guard/Riving Blade Assembly

PREPARING FOR USE

- Ensure cutter is on a flat surface.
- Always ensure that the guards are in place and in working order.
- Connect to electrical power point using an approved RCD circuit breaker. This is an essential safety precaution.
- For safety and motor life only switch the Tile Cutter on before cutting a tile.
- Switch off immediately after use.
- Use adequate eye and hand protection as specified.

USING THE PRO-TILER PLUS TILE CUTTER

- Remove the water reservoir cover/mitre guide. Fill with water to a depth of approx 20mm (7/8") or to the water level label enclosed. Replace the cover.
- Adjust splash guard up or down so that it is just above the tile surface.
- Fit the cutter guide to the top on either side with the lever up. Adjust the position and clamp to lock - Do not use undue force and ensure the lock is correctly located.
- Cutting widths can be set accurately by reading off the scale on the side adjacent to the wheel.

HINT

Intermittent use of the cutting wheel will prolong its life. Always stop and unclog the wheel at regular intervals.

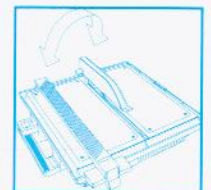
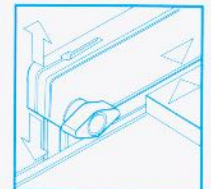
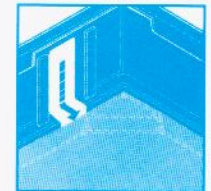

CUTTING STRAIGHT EDGES

Line up the tile where the cut is required, with the diamond cutting blade. Use the cutter guide alongside the tile edge for support. Push the tile towards the wheel, using steady and even pressure. Do not use excess pressure – if this is needed, check for alignment of the Riving Blade, Cutting Guide or check if the diamond wheel is worn.

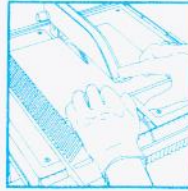

CUTTING 45° and 22.5° MITRES

Lift up the mitre guide and bend out the support legs so that they wedge into the top of the pillars on each side of the water reservoir. This is done by placing each thumb inside to spring out both legs together. **Place the tile face down** on the guide and push towards the wheel. Leave a small flat on the edge to avoid sharp edges and chips. This small flat can be varied by the adjustment of the gap between the guide and the cutting blade.

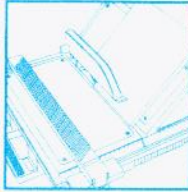

USING A PUSH STICK FOR SAFETY

When cutting very narrow strips, or cuts close to the diamond wheel, always use a push stick or piece of wood.

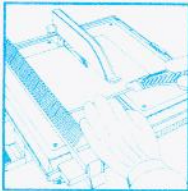

CUTTING CURVES, SQUARES AND CIRCLES

Gloves are recommended for this application. Draw the shape required onto the tile.

A chinagraph pencil is recommended for marking the tile (Ref.TMS854).

Lift up the splash guard and use the top of the wheel to cut your shape.

Recommended for advanced users only.



CARE & CLEANING

- Before cleaning, disconnect from the mains.
- Always clean sludge thoroughly from tray after use.
- Wash with a clean damp cloth. Do not use a water jet or hose.
- Keep the tile cutter free from oil and grease & store in dry conditions.
- No regular servicing is required. In the unlikely event of operating difficulty, please contact Plasplugs direct.

REPLACEMENT DIAMOND WHEEL BLADES

Always use Plasplugs genuine replacement blades.

Product code reference RDW110 or HGDW110.

Remove the water reservoir cover. Remove nut and large washer from shaft, then slide wheel up from below and place it on the shaft ensuring that the label/rotation arrow faces outwards. Refit washer and nut and tighten using a suitable spanner.

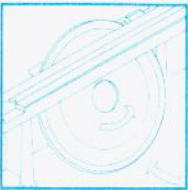

ONE YEAR GUARANTEE

Your Plasplugs product is guaranteed for one year from date of purchase, against electrical and mechanical defects in material and workmanship. Repairs or part replacement required as a result of such defects will be made free of charge during this period. Proof of purchase must be provided.

This guarantee does not cover damage caused by misuse, negligence or use on current or voltage other than that stamped on the product. The guarantee is invalid if the machine has been dismantled or interfered with in any way and persons other than Plasplugs' consumer care department have attempted repairs.

This guarantee is in lieu of any other warranty expressed or implied. This warranty does not affect your statutory rights.

For after sales care or any other additional questions you may have regarding Plasplugs tiling tool product range, please contact our free-phone number on 0800 243159.

TECHNICAL SPECIFICATION

Power Supply	~230V 50Hz
Power	375W
Geared Output	4600min (no load)
Max. Sound Power Level	90dB(A)
To cut	Ceramic, quarry, terracotta, slate, frost proof and marble tiles
Max. Cutting Depth	25mm
Max. Wheel Diameter	110mm

CERTIFICATE OF CONFORMITY

DWW110 PRO-TILER PLUS TILE CUTTER

I, the undersigned N.A. Turner of Plasplugs Limited, Wetmore Road, Burton-on-Trent, Staffordshire DE14 1SD, certify that the above product has been tested and found to comply with:

89/392/EEC machine safety directive

72/23 EEC low voltage directive

89/336/EEC EMC directive

VDE 0741:1963-08, VDE 0740-502:1992-12 (in reference)

EN 50144-2-5:1997-03 (sec. 7.1 & 18.101)

Signed

N.A. Turner

Burton-on-Trent November 2002